



TECHNICAL INFORMATION

TODD WATER CONTROL UNIT 3000

DST 220

The Todd Water Control Unit 3000 is an economical solution for the efficient management of water service during the embalming process. The WCU 3000 comes complete with a hydro-aspirator, hot and cold water embalming machine fill, and hot and cold water for the morgue table.

FEATURES

Space-saving, counter-mounted version

Quick-disconnects and 12' of tubing for aspirator and morgue table water

Custom fill spout riser heights, spout extensions, and wall braces available upon request

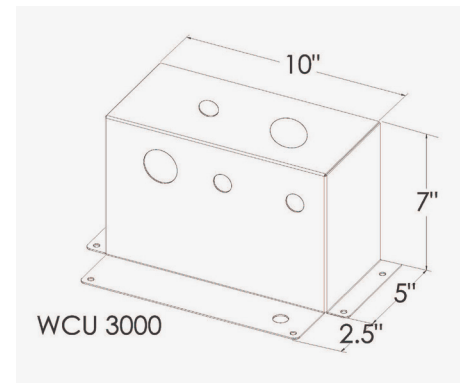

SPECIFICATIONS

Height of fill spout above counter varies. Add 4" to all heights for clearance required for mounting under upper cabinets

Weight: 12 lbs

Aspirator performance: 27-29# @ 65 psi

16-gauge stainless steel housing and chrome fittings



THE PREPARATION ROOM SPECIALISTS | SINCE 1991

TODD WATER CONTROL UNIT 3000 DST 220

INSTALLATION

Unit is supplied pre-assembled and pre-plumbed, except for gooseneck spout

Provide 1" cold water supply to aspirator and .5" hot & cold water supply to angle stops

Requires a minimum 1.5" waste line with p-trap connected directly to facility waste line

Supplied with stainless steel mounting hardware, template, and installation requirements

Install in accordance with all applicable codes

Flush all plumbing lines prior to start-up

AUXILIARY REQUIREMENTS FOR CODE COMPLIANCE

Reduced pressure backflow preventers required on cold and hot water lines

Mark piping to Todd WCU 3000 as non-potable per plumbing code requirements

AUXILIARY REQUIREMENTS FOR PROPER ASPIRATOR OPERATION

1" high pressure cold water line to the preparation room

Continuously operating water pressure of 65 minimum psi to aspirator

We recommend units be installed with a Volume Pressure Control System, DST 302

TODD WATER CONTROL UNIT 3000 DST 220

SCHEMATIC RISER DIAGRAM - STAND ALONE WCU 3000

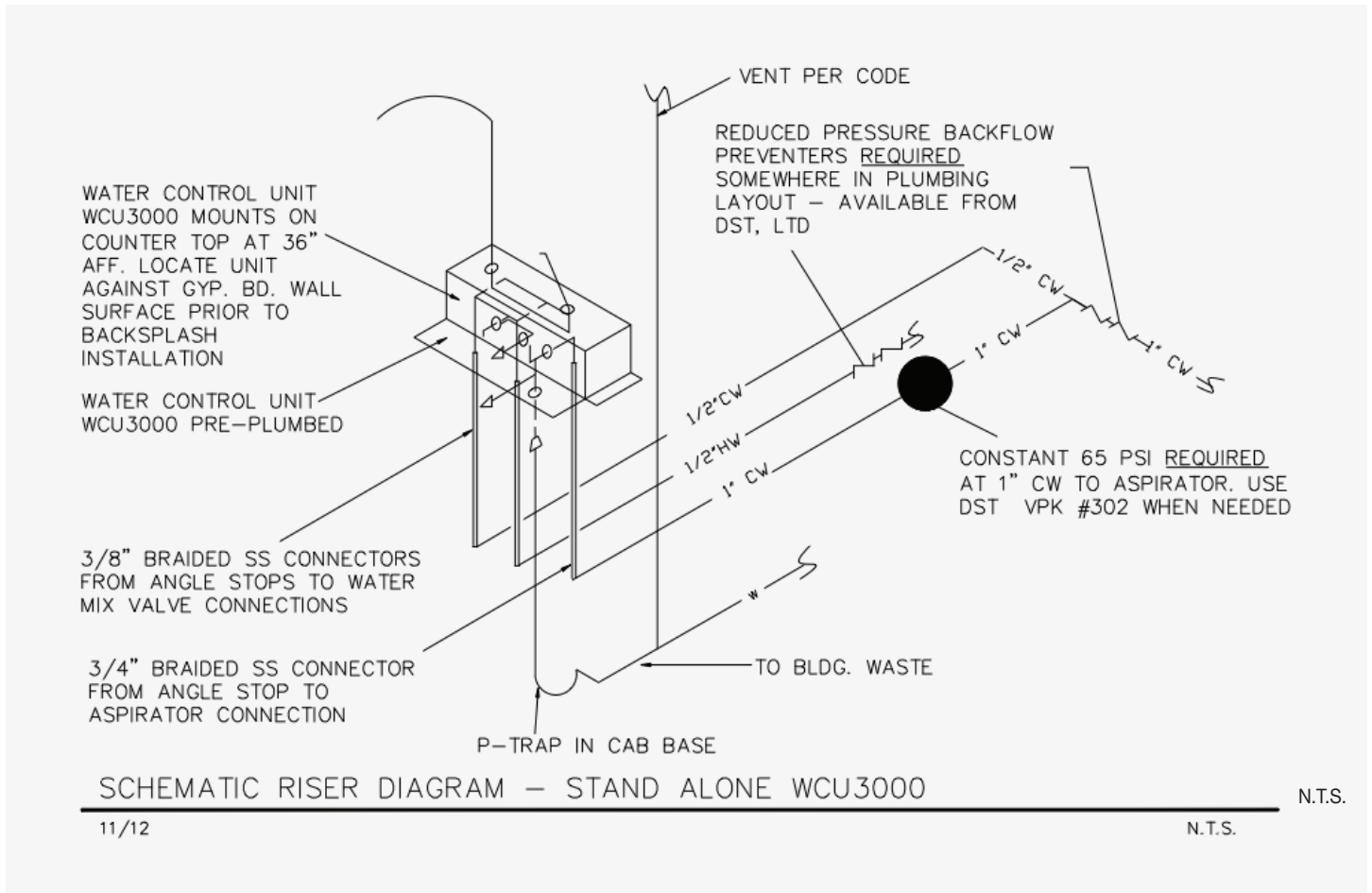

TODD WATER CONTROL UNIT 3000 DST 220

WATER CONTROL UNIT WASTE LINE CONFIGURATION

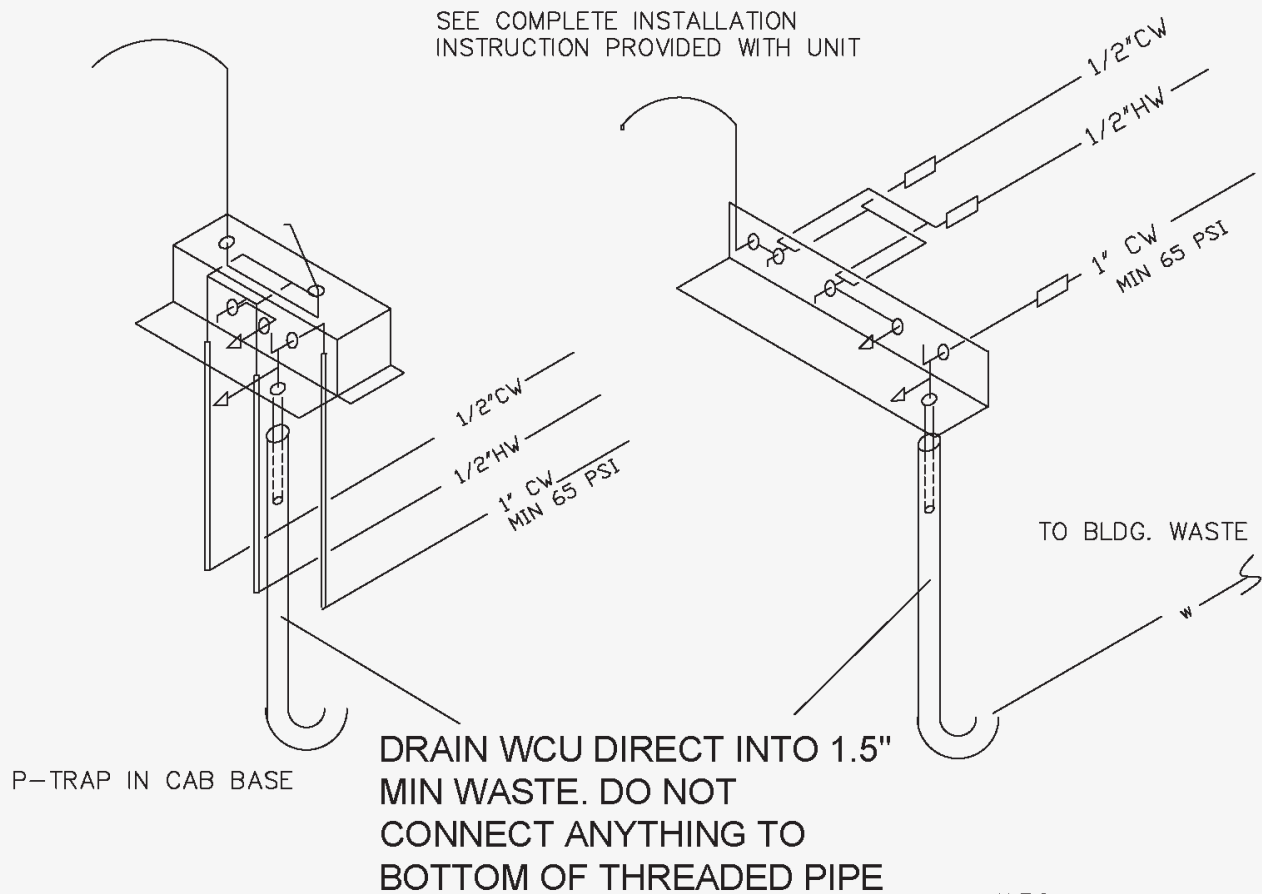

DO NOT CUT FACTORY SUPPLIED THREADED BRASS PIPE – VOIDS WARRANTY. SLEEVE FACTORY PIPE INTO 1½" BUILDING WASTE

DRAIN DIRECT INTO 1.5" MIN WASTE LINE FROM SUPPLIED THREADED PIPE DO NOT THREAD ANYTHING ONTO THE PIPE

IMPORTANT NOTICE REGARDING WATER CONTROL UNIT WASTE LINE CONFIGURATION

v1-18-16